



INSTALLATION MANUAL

Part I	Required Materials
Part II	Subfloor Preparation
Part III	Placing and Trimming FlexiKork™
Part IV	Installing FlexiKork™
Part V	Installation of Topping
Part VI	Installation of Baseboard
Part VII	Recommended Materials for Use with FlexiKork™
Part VIII	Warranty Information

The following recommendations for applications and installation are based on our extensive experience and on current technological practice. Our liability and responsibility in the event of damages are limited to the extent defined in our General Terms and Conditions of Business and are not in any way increased by the above recommendations or by advice given by our sales representatives or applications engineering staff.



1•866•554•4252

www.SignatureInnovations.com

1171 Landmeier Road, Elk Grove Village, IL 60007
Toll Free 866.554.4252 Local 847.758.9600 Fax 847.758.9696

www.FlexiKork.com
info@FlexiKork.com

©2003-2007 Signature Innovations, LLC. All Rights Reserved.
FlexiKork™ is a registered trademark of Signature Innovations, LLC.
FlexiKork™ is a licensed patented product.

This document may not be altered in any form or by any means.

No warranty of accuracy is given concerning the contents of the information contained in this publication. To the extent permitted by law, no liability (including liability to any person by reason of negligence) will be accepted by Signature Innovations, LLC, its subsidiaries or employees for any direct or indirect loss or damage caused by omissions or inaccuracies in this document.

Signature Innovations, LLC reserves the right to change details in this publication without notice.



INSTALLATION MANUAL

PART I -- REQUIRED MATERIALS

General: FlexiKork™ can be installed under most types of grouted and non-grouted flooring installations including ceramic tile, stone, marble, brick, pavers, hardwood, engineered wood, laminate, parquet, vinyl and carpet.

- A. FlexiKork™ (underlayment)
- B. FlexiKork™ Perimeter Isolation Strip (optional)
- C. Duct tape
- D. Carpet or utility knife

When using grouted flooring materials, such as ceramic tile, paver, brick, marble and stone, adhesive is also required.

E. Materials for Glue-Down Method:

- (1) A general-purpose adhesive. Select from approved adhesives listed in Part VII.
- (2) Trowel or brush, as required by adhesive manufacturer.
- (3) Extra-light 2-5 lb. roller

F. Materials for Thin-Set Method:

- (1) Thin-Set Polymer Modified Mortar. Select from list in Part VII.
- (2) Trowel, as required by mortar manufacturer.
- (3) 25-50 lb. roller



INSTALLATION MANUAL

PART II -- SUBFLOOR PREPARATION

General: FlexiKork™ can be installed under most types of grouted and non-grouted flooring installations including ceramic tile, stone, marble, brick, pavers, hardwood, engineered wood, laminate, parquet, vinyl and carpet.

FlexiKork™ may be installed over wood, concrete and masonry-type surfaces.

A. Wood Subfloors

Wood subfloors must be a minimum 1" thick double construction. Qualify deflection according to ANSI standards, as required by the finish floor manufacturer.

B. Concrete Floors

Slabs must be covered and wet-cured for a minimum of 28 days prior to the installation of FlexiKork™.

Areas that are to receive finished flooring, installed by the thin-set method, must have a wood-float finish -- true to within 1/8" (3mm) in 10' (3m) and pitched toward drains where required.

Areas requiring fill, patching or leveling must be prepared by the general contractor using Custom Building Products LevelQuik™ Self-Leveling Underlayment or LevelQuik™ Skim Coat and Patching Compound in accordance with the manufacturer's instructions.

C. Subfloors should be dry, clean, smooth, level and structurally sound. Subfloors must be free of dust, oil, solvent, paint, wax, oil, grease, asphalt, sealers, curing and hardening compounds, alkaline salts, old adhesive, residue and other extraneous materials according to ASTM F710.

D. If a waterproof membrane is required, specify Custom Building Products LevelQuik™ Waterproofing & Anti-Fracture Membrane.



INSTALLATION MANUAL

PART III -- PLACING AND TRIMMING FLEXIKORK™

General: FlexiKork™ can be installed under most types of grouted and non-grouted flooring installations including ceramic tile, stone, marble, brick, pavers, hardwood, engineered wood, laminate, parquet, vinyl and carpet.

It is essential to install optional FlexiKork™ Isolation Strip prior to placing and trimming FlexiKork™! Do not install baseboard until finished topping is installed.



- C. Remove the shrink-wrap from the roll of FlexiKork™ and unroll it onto the floor. Lay the material in such a way that you will use your cuts efficiently. Cut each roll to the required length.
- D. Lay the FlexiKork™ perpendicular to the subsequent installation direction of the topping material. (See Diagram #2)

- A. Glue the FlexiKork™ Perimeter Isolation Strip to the wall perimeter of the entire subfloor, as well as around the perimeter of any protrusions, in order to isolate or break the vibration transmission path between the floor and the wall. (See Diagram #1)

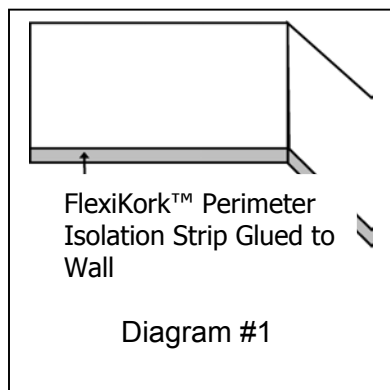

Glue the Perimeter Isolation Strip in place, using approved adhesive. See Part VII for list of adhesives.

- B. Make the assumption that the walls you are butting up against are *not* square. Using a chalk line, create a starting point for an edge of the material to follow.

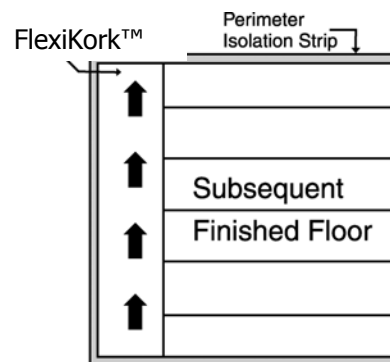

Diagram #2

- E. The ends of each section may be trimmed as necessary in order to fit the surface area to be covered. Trim section ends to exact dimensions required (e.g. joints with walls, etc.)
- F. Maintain the required ambient conditions for adhesive application and bonding.



INSTALLATION MANUAL

PART IV – INSTALLING FLEXIKORK™

General: FlexiKork™ can be installed under most types of grouted and non-grouted flooring installations including ceramic tile, stone, marble, brick, pavers, hardwood, engineered wood, laminate, parquet, vinyl and carpet.

A. Method #1: Glue Down

Full spread glue-down of FlexiKork™ is required for wood, ceramic tile, stone and marble installations.

- (1) Roll out a section of FlexiKork™ and fold the material back halfway.
- (2) Depending on the type of adhesive used, choose a suitable applicator (see Part I) and apply the adhesive evenly over the substrate.
- (3) Lay the FlexiKork™ into the wet adhesive. Do *not* allow the material to “flop” into place. This may cause air entrapment.
- (4) Immediately roll the floor using an extra-light 2-5 lb. roller to ensure proper adhesive transfer. Overlap each roll of the roller 50% of the previous pass. Roll the width first, then the length.
- (5) Fold the second half of the roll back over the first half of the material. Spread the adhesive at right angles to the seams in order to prevent the adhesive from oozing up through the seam.
- (6) Make sure the lengthwise edge of the material is aligned exactly with that of the neighboring section. Edges must contact but *not* overlap. **(See Diagram #3)**

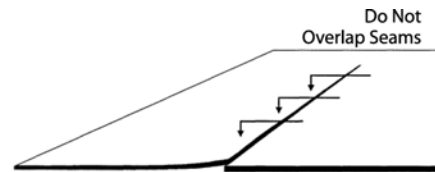

Diagram #3

- (7) Repeat procedure for the next section of FlexiKork™.
- (8) Fix problem areas (e.g. over stairs, contours and edges) in place using adhesive.

B. Method #2: Thin-Set Polymer Modified Mortar *(Alternative to Method #1)*

- (1) Apply specified mortar (see Part VII) as directed.
- (2) Apply only enough mortar as can be covered with FlexiKork™ within a 20-30 minute time period.
- (3) Roll FlexiKork™ into place. Once set, use a 25-50 lb. roller to set FlexiKork™ in place.

C. Method #3: Tape Down

Glue or thin-set fixing of the FlexiKork™ is not required but is recommended for non-grouted flooring material installations.

- (1) Dry lay the rolls onto the subfloor using the Placing and Trimming Method described in Part III.
- (2) Use duct tape or a high-quality carpet tape to secure the butt joints and seams.



INSTALLATION MANUAL

PART V -- INSTALLATION OF TOPPING

General: FlexiKork™ can be installed under most types of grouted and non-grouted flooring installations including ceramic tile, stone, marble, brick, pavers, hardwood, engineered wood, laminate, parquet, vinyl and carpet.

A. Plywood / Wonderboard™

- (1) The board should be glued down using an approved adhesive (see Part VII for list of adhesives).
- (2) Apply adhesive to the FlexiKork™ and the board surface simultaneously using a trowel or roller as recommended by the adhesive manufacturer's installation instructions. Only apply as much adhesive to the FlexiKork™ as can be covered by the board.
- (3) If the board is porous, a second coat may need to be applied.

Do not mechanically fasten the boards to the FlexiKork™ using nails or staples. Any hard connection may transmit vibration and, therefore, sound through to the building structure compromising the construction.

B. Vinyl

Before covering FlexiKork™ with VCT floor coverings, coat FlexiKork™ with troweled-on elastic sealing compound E-Grip II available from Signature Innovations, LLC

- (1) Consult Signature Innovations', LLC Engineering Department for details.

C. Ceramic Tile or Stone

Before covering FlexiKork™ materials that are greater than 10mm thick (3/8" thick) with grouted floor coverings, a monolithic reinforcing layer may be required for certain FlexiKork™ types to ensure proper load distribution. Consult Signature Innovations' LLC Engineering Department for details.

- (1) Apply selected dry-set mortar (Part VII) over FlexiKork™, as directed by mortar manufacturer.
- (2) Do not spread more mortar than can be covered in a 20-30 minute time period.
- (3) Tap or beat the tile into place to ensure 90-100% coverage. Remove a tile periodically to check for adequate coverage.

D. Wood

- (1) Place and fix floor covering, carefully observing floor covering manufacturer's instructions.
- (2) Follow all manufacturers' recommendations and instructions for the adhesive cement.



INSTALLATION MANUAL

PART VI -- INSTALLATION OF BASEBOARD

General: FlexiKork™ can be installed under most types of grouted and non-grouted flooring installations including ceramic tile, stone, marble, brick, pavers, hardwood, engineered wood, laminate, parquet, vinyl and carpet.

If a baseboard is required, install the baseboard *after* the finished floor has been installed.

- A. After the finished floor is installed, trim the excess FlexiKork™ Perimeter Isolation Strip around the entire perimeter of the finished floor. (See **Diagram #4**)

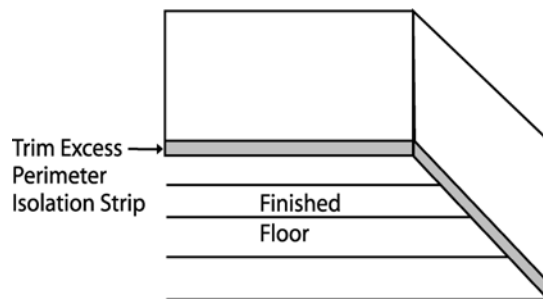
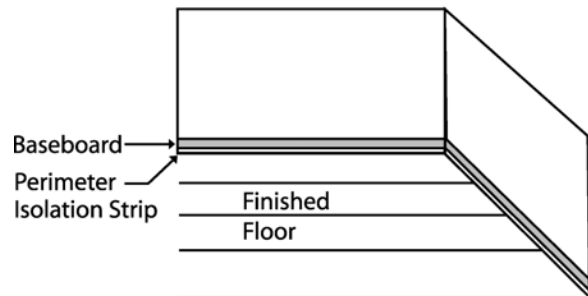

Diagram #4

- B. Nail the baseboard to the wall above the Perimeter Isolation Strip. In order to isolate or break the vibration transmission path between floor and wall, the baseboard must not touch the finished floor. (See **Diagram #5**)



Do Not Allow Baseboard To Touch Finished Floor

Diagram #5



INSTALLATION MANUAL

PART VII -- RECOMMENDED MATERIALS

I. RECOMMENDED GENERAL-PURPOSE POLYURETHANE ADHESIVES

A. **Uzin® MK-97 by Uzin-Utz
Germany (Recommended)**

B. Uzin® MK-100 by Uzin-Utz
Germany

C. Synthetic Surfaces' 78H or 33C

D. Helmicol 3078 by Helmitin

E. Bostik's Best by Bostick

F. Chemrex 941

G. ParaBond M4700 by Parachem

H. Chapco 399

I. Capitol USA Fast 050

(2) PorcelainPro – single
component modified mortar

(3) MasterBlend™ Dry Set
Mortar with Acrylic Mortar
Admix – two-component
setting system

(3) FlexBond® – high
performance single-
component setting system

B. Mortar Admixture and Grout
Adhesive. Select one:

(1) Polyblend® – polymer
modified grout available in
standard or designer colors

(2) 100% Solids Epoxy Grout –
for maximum stain and wear
resistance

II. RECOMMENDED GROUTED MATERIALS

A. Multi-purpose Latex Modified
High Performance Mortar.
Select one (1) each for
FlexiKork™ and tile
installation:

(1) Versabond™ – single
component polymer modified
mortar

C. All preparation, setting and
grouting materials are to be
manufactured by Custom Building
Products, 13001 Seal Beach Blvd.,
Seal Beach, CA 90740.

D. All materials shall be delivered to
the job site in the original
containers with the manufacturer's
identification on each package.
Unauthorized modification to any
product is not permitted.

Signature Innovations, LLC, reserves the right to update or modify this page without notice. Further more, Signature Innovations, LLC does not offer any warranty on any recommended materials or products. For warranty issues please contact the actual manufacturer of the product.



PART VIII -- WARRANTY INFORMATION

Signature Innovations, LLC, products are manufactured from the highest quality raw and recycled materials available. All of our specialty products are manufactured in the world's most technically advanced factories. A full range of warranties provided by the domestic & foreign manufacturers also support our products.

The recommendations for applications and installation are based on our extensive experience and on current technological practice. Our liability and responsibility in the event of damages are limited to the extent defined in our General Terms and Conditions of Business and are not in any way increased by the above recommendations or by advice given by our sales representatives or applications engineering staff. Signature Innovations, LLC is a company duly organized and validly existing under the laws of the Illinois State. Signature Innovations, LLC offers a limited lifetime warranty on the FlexiKork™ brand of Impact Sound Insulation products against defects in material and workmanship and that FlexiKork™ shall perform effectively. Signature Innovations, LLC warrants that during the warranty period FlexiKork™ shall not harden, become brittle, chip, crack, tear or exhibit any signs of excessive deterioration except for normal wear and tear. All other warranties including implied warranties for a particular purpose are expressly excluded. The sole remedy against the seller will be the replacement or repair of the defective goods, or at seller's option, credit may be issued not exceeding the selling price of the defective goods.

Quality Products by



**For more information and samples call
1•866•554•4252
or visit www.FlexiKork.com**

1171 Landmeier Road, Elk Grove Village, IL 60007
Toll Free 866.554.4252 Local 847.758.9600 Fax 847.758.9696
**www.FlexiKork.com
info@FlexiKork.com**

©2003-2007 Signature Innovations, LLC. All Rights Reserved.

FlexiKork™ is a registered trademark of Signature Innovations, LLC. FlexiKork™ is a licensed patented product.

Bostik and Bostik's Best is a registered trademark of Bostik. Capitol is a registered trademark of Capitol USA. ParaBond and Parachem are registered trademarks of Parachem. Custom Building Products is a registered trademark of Custom Building Products. MasterBlend, VersaBond and FlexBond are all registered trademarks of Custom Building Products. CustomFlex is a trademark of Custom Building Products. Laticrete is a registered trademark of Laticrete International, Inc. TEC, Sturdi Flex, Full Flex, and Super Flex are trademarks of Specialty Construction Brands. UZIN is registered trademark of Uzin Utz AG.